

MiniMAC

user manual



MiniMAC Wash



MiniMAC Profile

- 1 data connection
- 2 base fan
- 3 head fan
- 4 AC input & main fuse
- 5 cover locks
- 6 lamp access
- 7 control panel
- 8 eye bolt for safety cable
- 9 Omega clamp attachment bracket

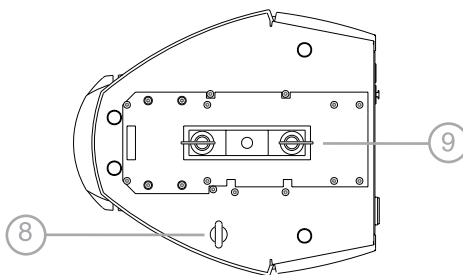
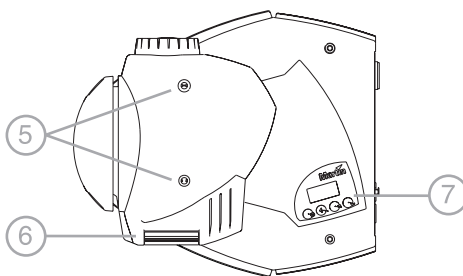
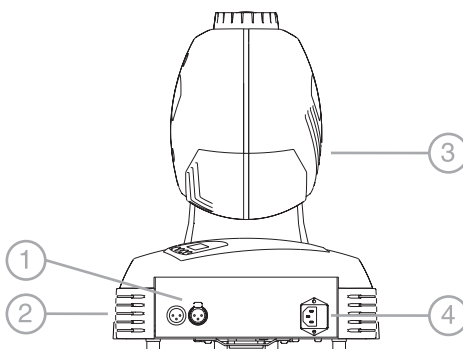

©1999 - 2000 Martin Professional A/S, Denmark.

All rights reserved. No part of this manual may be reproduced, in any form or by any means, without permission in writing from Martin Professional A/S, Denmark.

Printed in Denmark.

P/N 35000084, Rev. D

INTRODUCTION 4
AC POWER 6
INSTALLATION 8
CONTROL PANEL 10
CONTROLLER OPERATION 18
AUTOMATIC STAND-ALONE 21
PROGRAMMED STAND-ALONE 24
LAMP 28
GOBOS 30
WASH FIELD ANGLE 32
BASIC SERVICE 33
TROUBLESHOOTING 37
DMX PROTOCOL 38
SPECIFICATIONS 41

INTRODUCTION

Thank you for selecting the Martin MiniMAC Profile or MiniMAC Wash. Both of these automated luminaires provide 12 dichroic color filters, high-speed mechanical shutter, 540° of pan by 270° of tilt, 3-digit LED control panel, DMX, MC-1, stand-alone, and master/slave control options; and switch-selectable power supply settings. The MiniMAC Profile provides a 17° hard-focused beam, manually adjustable focus, and 7 interchangeable rotating gobos. The MiniMAC Wash provides a soft-edged, user-selectable 23° or 40° beam.

SAFETY INFORMATION

Warning! *This product is for professional use only. It is not for household use.*

This product presents risks of lethal or severe injury due to fire and heat, electric shock, ultraviolet radiation, lamp explosion, and falls. **Read this manual** before powering or installing the fixture, follow the safety precautions listed below and observe all warnings in this manual and on the fixture. If you have questions about how to operate the fixture safely, please contact your Martin dealer or call the Martin 24-hour service hotline at +45 70 200 201.

To protect yourself and others from electric shock

- Disconnect the fixture from AC power before removing or installing the lamp, fuses, or any part, and when not in use.
- Always ground (earth) the fixture electrically.
- Use only a source of AC power that complies with local building and electrical codes and has both overload and ground-fault protection.
- Do not expose the fixture to rain or moisture.
- Refer all service to a Martin service technician.

To protect yourself and others from UV radiation and lamp explosion

- Never operate the fixture with missing or damaged lenses and/or covers.

- When replacing the lamp, allow the fixture to cool for at least 5 minutes before opening the fixture or removing the lamp. Protect your hands and eyes with gloves and safety glasses.
- Do not stare directly into the light. Never look at an exposed lamp while it is lit.
- Replace the lamp if it becomes defective or worn out.

To protect yourself and others from burns and fire

- Never attempt to bypass the thermostatic switch or fuses. Always replace defective fuses with ones of the specified type and rating.
- Keep all combustible materials (for example fabric, wood, paper) at least 0.3 meters (12 inches) away from the fixture. Keep flammable materials well away from the fixture.
- Do not illuminate surfaces within 0.3 meters (12 inches) of the fixture.
- Provide a minimum clearance of 0.1 meters (4 inches) around fans and air vents.
- Never place filters or other materials over the lens.
- The exterior of the fixture can reach temperatures up to 60° C (140° F). Allow the fixture to cool before handling.
- Do not modify the fixture or install other than genuine Martin parts.
- Do not operate the fixture if the ambient temperature (Ta) exceeds 40° C (104° F).

To protect yourself and others from injury due to falls

- When suspending the fixture above ground level, verify that the structure can hold at least 10 times the weight of all installed devices.
- Verify that all external covers and rigging hardware are securely fastened and use an approved means of secondary attachment such as a safety cable.
- Block access below the work area whenever installing or removing the fixture.

UNPACKING

The packing material is carefully designed to protect the fixture during shipment - always use it to transport the fixture.

The MiniMAC comes with:

- Martin Metal Halide 150 lamp
- 3 m, 3-pin IEC mains cable
- 5 m, black, 3-pin XLR data cable
- Attachment bracket for mounting clamp
- Eye bolt for safety cable
- User manual

The MiniMAC has switch-selectable settings to configure the power supply for local conditions. The factory-default setting is indicated on the serial number label. Always use the setting that is closest to the local AC supply.

Warning! *For protection from electric shock, the fixture must be grounded (earthed). The power supply shall have overload and ground-fault protection.*

Important! *Install fuse and verify that power supply settings match local AC supply before use.*

To change the voltage setting

- 1 Disconnect the fixture from power.
- 2 Remove the 4 base cover bolts with a 4 mm Allen wrench. Move the cover out of the way of the switches without disconnecting wires.

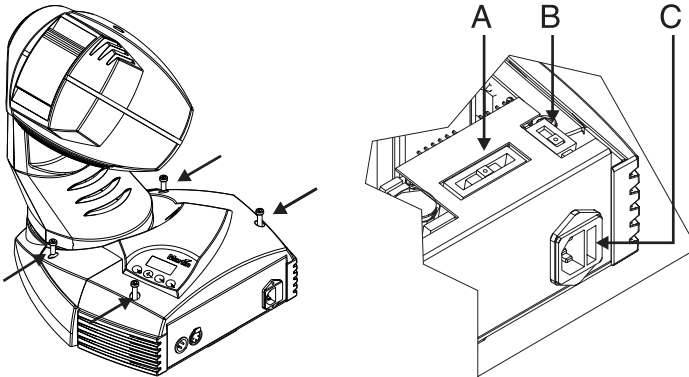

- 3 Set the 5-position switch (A) to the setting closest to the AC voltage. Use the higher setting if the voltage is halfway between 2 settings. For example, use the 230 V setting instead of the 210 V setting for operation with 220 V power.
- 4 Set the 2-position switch (B) to the AC frequency (50 / 60 Hz).
- 5 Replace the cover and apply a new power setting label to the serial number label.

To install the main fuse

Fuses are provided for 100 - 130 V and 200 - 250 V operation. *Use only the fuse specified for the operating voltage.*

- 1 Locate the bag containing the fuse for your AC voltage. Insert the fuse in the fuse holder. The holder may be packed with the other fuse.
- 2 Remove the label covering the mains input socket.
- 3 Insert the fuse holder in the empty slot in the mains input socket (C).

To install a plug on the power cable

The power cable must be fitted with a grounding-type cord cap that fits your power distribution system. Consult an electrician if you have any doubts about proper installation.

- Following the cord cap manufacturer's instructions, connect the yellow and green wire to ground (earth), the brown wire to live, and the blue wire to neutral. The table below shows some pin identification schemes.

Wire	Pin	Marking	Screw color
brown	live	"L"	yellow or brass
blue	neutral	"N"	silver
yellow/green	ground		green

Table 1: Cord cap connections

To apply power

Warning! *The power cables must be undamaged and rated for the electrical requirements of all connected devices.*

Important! *Powering through a dimmer system can damage the fixture.*

- Connect the prepared cable to the mains input socket and the AC mains distribution system. Do not connect the fixture to a dimmer system.

INSTALLATION

LOCATION AND ORIENTATION

For safe operation, install the MiniMAC in a location where

- it is at least 0.3 meters (12 inches) away from illuminated surfaces and combustible materials.
- it is not easily touched or bumped.
- it is protected from rain and moisture.
- there is at least 0.1 meters (4 inches) clearance around the fans and air vents.
- there are no flammable materials nearby.

The MiniMAC may be installed in any orientation by means of a rigging clamp (not included) or placed directly on a stage or floor.

The intense light can burn or melt parts within a distance of 0.3 meters (12 inches). The MiniMAC is programmed to close its shutter if it illuminates its own base for more than 10 seconds. *When installing fixtures side-by-side, avoid illuminating one fixture with another.*

RIGGING

The MiniMAC includes a bracket for attaching a rigging clamp with 12 mm (1/2 in.) hardware. Clamps available from Martin are listed on page 42.

To rig the fixture

WARNING! *Screw the included eye bolt securely into the base and fasten a safety cable to the eye bolt.*

- 1 Verify that the clamp is undamaged and can bear at least 10 times the weight of the fixture. Verify that the structure can bear at least 10 times the weight of all installed fixtures, clamps, cables, auxiliary equipment, etc.
- 2 Bolt a clamp to the included bracket with a grade 8.8 (minimum) M12 bolt and lock nut, or as recommended by the clamp manufacturer, through the 13 mm hole in the bracket.

- 3 Align the bracket with the keyholes in the base. Insert both locking pins into the holes and turn both levers a full 1/4 turn clockwise to lock. *The fasteners are locked only when turned fully clockwise.*
- 4 Screw the eye bolt securely into the base as shown below.
- 5 Block access below the work area.
- 6 Working from a stable platform, clamp the fixture to the structure.
- 7 Fasten a safety cable that can bear at least 10 times the weight of the fixture to the structure and the eye bolt.

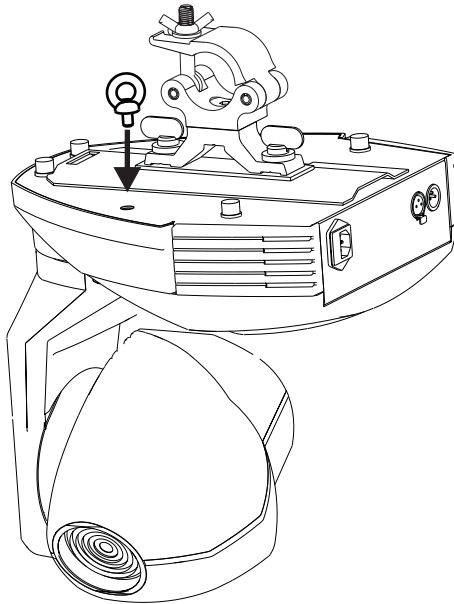

CONTROL PANEL

The control panel is used to set control modes, address, and personalities; to display information readouts, to run tests, and to control the fixture manually.

All user options may be set remotely via the serial link using the Martin MPBB1 Uploader with version 1.4 or later software.

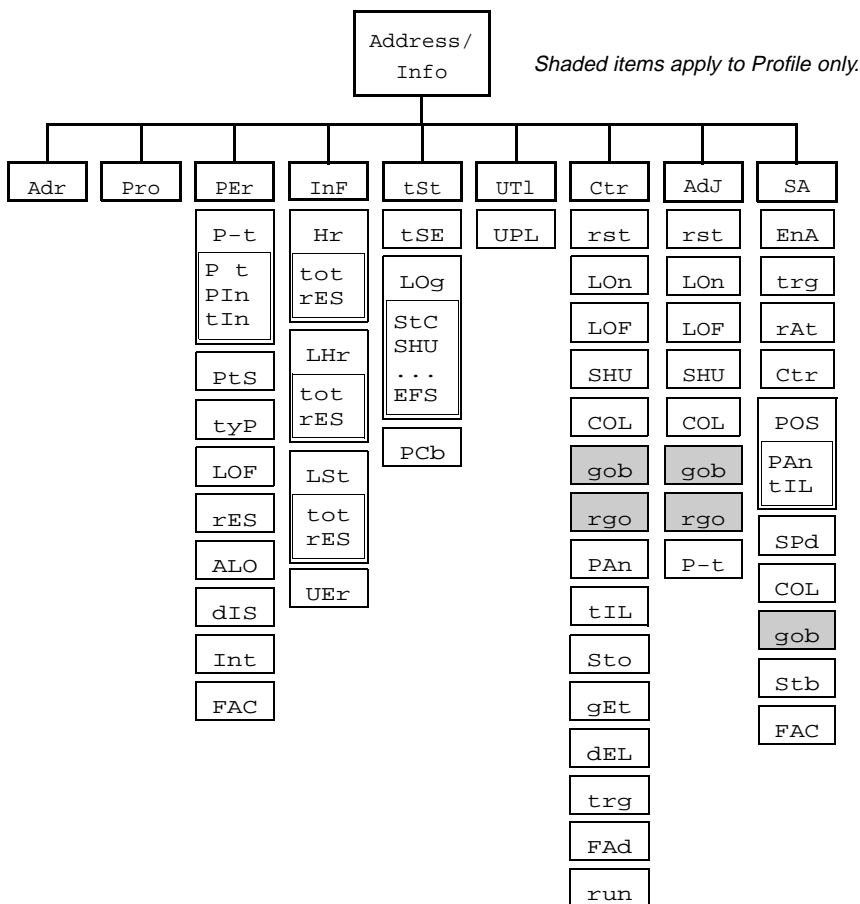

To navigate the control menu

Error messages, if any, and mode information are displayed at the top of the menu tree. If the fixture is in (1) DMX mode, the address is displayed; (2) Automatic Stand-alone mode, SA is displayed; (3) Programmed Stand-alone mode, the scene number is displayed. The top of the menu can be reached by pressing [menu] repeatedly.

- 1 From the top of the control menu, press [menu] to enter the main menu.
- 2 Press [up] or [down] to scroll through menus and press [enter] to view submenus.
- 3 To activate a setting or function, press [enter].
- 4 To return to the previous menu or to escape without making a selection, press [menu].



To invert the display

- Press [up] and [down] at the same time.

Adj	adjustment menu	POS	position
Adr	address	Pro	protocol, profile
ALO	automatic lamp on	P-t	pan/tilt menu
Aut	auto-trigger	PtS	pan/tilt speed
COL	color	rAt	rate
Ctr	manual control, SA control	rEC	receive (SA slave)
dEL	delete	rES	DMX reset
dIS	display	rgo	gobo rotation
EnA	enable	rnd	random
FAC	factory settings	rst	reset fixture
FAd	fade time	SA	stand-alone menu
FrE	Fresnel (MiniMAC Wash)	SHU	shutter
FSt	fast	SLO	slow
get	get (retrieve scene)	Snd	sound, send (SA master)
gob	gobo selection	SPd	speed
Hr	hours	Stb	strobe
InF	information menu	StC	start code
Int	intensity (dimmer)	StE	settings error
Inu	inverse	Sto	store
LHr	lamp hours	SUr	sure?
LOF	lamp off	tIE	tilt error time-out
LOg	DMX log	tIF	tilt fine
LOn	lamp on	tIL	tilt
LSt	lamp strikes	tIn	inverse tilt
nor	normal (medium)	tot	total
P t	pan/tilt swap	trg	trigger, wait time
PAE	pan error time-out	tSE	test sequence
PAF	pan fine	tSt	test menu
PAn	pan	tyP	fixture type
PCb	printed circuit board	UEr	software version
PEr	personalities	UPL	upload
PIn	inverse pan	Utl	utilities menu

Table 2: Menu abbreviations

DMX MODE SETTING

The MiniMAC has 4 control modes for operation with DMX512 controllers. The modes mix tracking and vector control with 8 and 16-bit pan/tilt resolution in different combinations to minimize channel requirements. Mode 1 provides basic control and requires the fewest channels. Modes 2 and 3 provide some additional control options. Mode 4 provides the full set of control options.

TRACKING VERSUS VECTOR CONTROL

With tracking control (all modes) the speed at which an effect changes from one position to another (fades) is determined by programming a fade time between 2 scenes using a cross-fader.

With vector control (modes 3 and 4), speed is programmed on separate speed channels. This provides a way to program fades on controllers without cross-faders. With some controllers, vector control provides smoother movement than tracking control, particularly at slow speeds.

The speed channel must be set to “tracking speed” when using a cross-fader (tracking control) to program fades.

The speed channels also provide a “blackout speed” that causes the shutter to close while the effect is moving in order to make the transition invisible.

8-BIT VERSUS 16-BIT PAN/TILT RESOLUTION

8-bit pan/tilt resolution (modes 1 and 3) divides the pan and tilt ranges into 1 - 2° increments. 16-bit resolution (modes 2 and 4) divides pan into 0.013° steps and tilt into 0.007° steps for finer position control and smoother movement.

Mode	Control	Resolution	MiniMAC Wash	MiniMAC Profile
1	Tracking	8-bit	4 channels	6 channels
2	Tracking	16-bit	6 channels	8 channels
3	Tracking/Vector	8-bit	6 channels	8 channels
4	Tracking/Vector	16-bit	8 channels	10 channels

Table 3: DMX mode summary

To select DMX mode

- 1 Scroll to **P r o** in the main menu, press [enter], and scroll to the desired mode.
- 2 Press [enter] to activate the setting and return to the main menu.

ADDRESS SELECTION

The control address, also known as the start channel, is the first channel used to receive instructions from the controller. The total number of channels used depends on the control mode.

Be sure to allow adequate channels when setting the control address. If control channels for one fixture overlap control channels for another fixture, then one of the fixtures will receive the wrong commands. To find the highest usable address channel, subtract the number of channels required from the last controller channel and add 1.

Two MiniMACs of the same type, and operating in the same control mode, may share the same address if they are to respond identically. They will receive the same commands and individual control will be impossible.

To set the control address

- 1 Scroll to **Adr** in the main menu and press [enter]. The current address is displayed.
- 2 Scroll to the address that is assigned to the fixture on the controller. Press [enter] to activate the address setting.

PERSONALITIES

The following settings are available to modify fixture behavior.

Pan/tilt swap: Map pan to the tilt channel and tilt to the pan channel to provide more intuitive control of fixtures mounted sideways.

Inverse pan: Flip pan movement to right-to-left instead of left-to-right.

Inverse tilt: Flip tilt movement to down-to-up instead of up-to-down.

Pan/tilt speed: Optimize motor control for speed or smoothness.

Profile/Wash: For service use only - initializes software for fixture type.

DMX lamp-off: Disable the lamp-off command unless color 12 (Blue 108) is selected and, on the Profile, gobo 7 (Sunburst 507) is selected.

DMX reset: Disable the reset command unless color 12 (Blue 108) is selected and, on the Profile, gobo 7 (Sunburst 507) is selected.

Automatic lamp-on: Strike lamps automatically within 90 seconds of applying power to the fixture. Timing is staggered to prevent excessive current draw.

Display: Turn off the display 2 minutes after the last key press or leave it on.

Intensity: Enable shutter fade function.

To select a personality setting

- 1 Scroll to **P E r** in the main menu, press [enter], scroll to the desired personality, and press [enter].
- 2 Scroll to the desired option and press [enter].

To restore default personality settings

- Scroll to **P E r** in the main menu, press [enter], and scroll to **F A C**. Press [enter] twice to confirm and execute the command.

Personality	Path	Option	Effect (Default setting bold)
Pan/tilt swap	P - t / P t	ON	Map pan to tilt channel and vice versa.
		OFF	Select normal pan and tilt control.
Inverse pan	P - t / P I n	ON	Reverse pan control (right → left).
		OFF	Select normal pan (left → right).
Inverse tilt	P - t / T I n	ON	Reverse tilt control (down → up).
		OFF	Select normal tilt (up → down).
Pan/tilt speed	P t S	F S t	Optimize movement for speed.
		S L O	Optimize movement for smoothness.
Profile/Wash	t Y P	P r o	Initialize MiniMAC Profile.
		F r E	Initialize MiniMAC Wash.
DMX lamp off	L O F	ON	Enable lamp-off without confirmation.
		OFF	Require confirmation of lamp-off.
DMX reset	r E S	ON	Enable reset without confirmation.
		OFF	Require confirmation of reset command
Automatic lamp on	A L O	ON	Strike lamp automatically within 90 seconds.
		OFF	Strike lamp from controller.
Display	d I S	ON	Keep display lit.
		OFF	Turn display off 2 minutes after key press.
Intensity	I n t	ON	Enable shutter fade.
		OFF	Disable shutter fade.

Table 4: Personalities

READOUTS

The MiniMAC provides readouts to track usage, maintenance intervals, lamp life, and software version. Values from 1000 to 9999 are automatically scrolled and counters reset to 0 when they reach 10,000.

Readout	Path	Option	Displays
Usage	Inf / Hr	tot	Total hours with power on.
		res	Hours with power on since counter was reset. Recommended for tracking service intervals.
Lamp usage	Inf / LHr	tot	Total hours with lamp on.
		res	Hours with lamp on since counter was reset. Recommended for tracking lamp life.
Lamp strikes	Inf / LSt	tot	Total number of lamp strikes.
		res	Lamp strikes since counter was reset. Helps evaluate lamp life.
Software version	Uer	-	Version number of installed software.

Table 5: Readouts

To display or reset a readout

- 1 Scroll to `Inf` in the main menu, press [enter] and scroll to the desired readout. Press [enter] and scroll to the desired option. Press [enter] to display the information.
- 2 (Optional) To reset a counter, press [up] until the readout displays 0.

TEST PROGRAMS

Test sequence: This provides an easy way to test all effects without a controller. Effects return to their home position at the end of the sequence before the test repeats. To run the test, navigate to `tSt / tSE / run` and press [enter]. To stop the test, press [menu].

DMX log: Displays the start code and the DMX value received for each effect. This is useful for troubleshooting set-up errors. For example, if the fixture is programmed for red but projects blue, check the DMX log to find the value received for color. If the value is for red (see the DMX protocol on page 38) then there is a problem with the fixture. If the value is for blue, then the problem is with the programming, set-up, or link.

PCb: For service use only. *Executing this test with motors connected may cause damage to the circuit board.*

To test DMX control values

- 1 Program a set of commands for the fixture.
- 2 Scroll to tSt in the main menu, press [enter] and scroll to L O g . Press [enter].
- 3 Press [enter] to display the start code. The start code must be 0. Press [menu].
- 4 Scroll through the effects and press [enter] to display the DMX values received. Compare the values with the DMX protocol.

UPLOAD MODE

Software upload mode is normally engaged automatically. Use this option only if automatic upload fails. See “Installing software” on page 34.

MANUAL CONTROL

The manual control menu (C t r) provides limited manual operation and is used to program and execute scenes as described under “Programmed Stand-alone” on page 24. The lamp strikes automatically when you enter the menu.

- To reset the fixture, select r S T.
- To turn the lamp on or off, select L O n or L O F.

See Table 7 on page 25 for additional options.

ADJUSTMENT CONTROL

The adjustment menu (A d J) provides manual control for service use.

AUTOMATIC STAND-ALONE CONTROL

The MiniMAC can be operated without a controller in Automatic Stand-alone mode; see page 21.

CONTROLLER OPERATION

5

This section describes operation with DMX controllers. The MiniMAC is also compatible with the Martin MC-1 and MC-X controllers.

Controller operation is disabled when a stand-alone mode is enabled.

DATA CONNECTION

RECOMMENDED CABLE

Reliable data communication begins with the right cable. Most microphone cable does not transmit digital data reliably over long runs. For best results, use shielded, twisted-pair cable designed for RS-485 applications with low capacitance and a characteristic impedance of 85 to 150 ohms. The minimum wire size is 0.2 mm (24 AWG) for runs up to 300 meters (1000 ft.) and 0.322 mm (26 AWG) for runs up to 500 meters (1640 ft.).

Your Martin dealer can supply the right cable in various lengths.

CONNECTIONS

The XLR data sockets are wired pin 1 to ground, pin 2 to signal - (cold), and pin 3 to signal + (hot). This is the standard pin assignment for DMX devices.

One or more adaptor cables may be required to connect the MiniMAC to the controller and other lights if they have 5-pin connectors or reversed signal polarity on pins 2 and 3.

5-pin to 3-pin Adaptor	
Male	Female
1	1
2	2
3	3
4	
5	
P/N 11820005	

3-pin to 5-pin Adaptor	
Male	Female
1	1
2	2
3	3
	4
	5
P/N 11820004	

3-pin to 3-pin Phase-Reversing Adaptor	
Male	Female
1	1
2	3
3	2
P/N 11820006	

To connect for controller operation

- 1 Connect a data cable to the controller's data output. If controller has a 5-pin output, use a 5-pin male to 3-pin female adaptor cable (P/N 11820005). Lead the cable from the controller to the first fixture and plug it into the data input.
- 2 Connect the output of the fixture closest to the controller to the input of the next fixture. If connecting to a fixture with reversed-polarity (pin 3 cold), insert a phase-reversing cable between the two fixtures.
- 3 Continue connecting fixtures output to input. Up to 32 devices may be connected on a serial link.
- 4 Terminate the link by inserting a male termination plug (P/N 91613017) into the data output of the last fixture. A termination plug is simply an XLR connector with a 120 ohm, 0.25 W resistor soldered across pins 2 and 3.

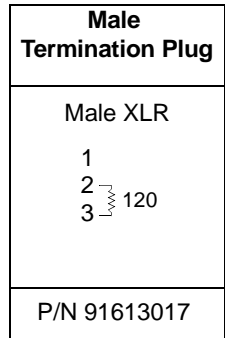

CONTROLLABLE EFFECTS

LAMP POWER

Lamp power can be switched on and off from the controller. *When set-up for controller operation, and with the automatic lamp-on personality set to off, the lamp remains off until a lamp-on command is sent.*

Note: A peak of electric current many times the operating current is drawn briefly when striking a lamp. Striking many discharge lamps at once may cause a voltage drop that prevents lamps from striking or trips circuit breakers. When striking multiple fixtures, space lamp-on commands at 5 second intervals.

The lamp must be allowed to cool for several minutes after turning it off before it can be turned back on. To prevent accidental lamp-off commands, this command can be partially disabled from the control panel: see page 14. If a hot lamp does not strike, send the lamp off command and wait several minutes before trying again.

RESET

All effects can be reset to their index positions from the controller. To prevent accidental resets, the command can be partially disabled from the control panel: see page 14.

SHUTTER

The mechanical shutter opens, closes, and strobes at variable and random rates up to 11.4 Hz. It also provides an optional low-resolution dimmer function that can be enabled by toggling the intensity personality setting (P E r / I n t) to ON.

The shutter closes automatically after 10 seconds if the light beam is projected on the base to prevent heat damage. The shutter opens instantly when the beam is moved.

STAND-ALONE MODE

Automatic stand-alone operation may be activated from the controller.

COLOR

The color wheel provides continuous-scroll for split-color effects and stepped-scroll for full-color positions. The wheel rotates continuously at variable speed and provides a random color function.

GOBOS

The MiniMAC Profile provides 7 interchangeable gobos that shake, swing, and rotate at variable speed. The wheel also provides a random gobo function.

PAN AND TILT

The head pans 540° and tilts 270°. If knocked or jarred out of position, pan and tilt are reset automatically when the head reaches one of its limits.

AUTOMATIC STAND-ALONE

The MiniMAC provides two stand-alone modes: automatic and programmed. In Automatic Stand-alone mode, the action is sound activated, using a built-in microphone, or triggered by a timer. The pan/tilt range and speed are adjustable and multiple fixtures may be synchronized in master/slave configuration. Table 6 lists the options and menu settings for customizing operation.

Several MiniMACs may be connected together for synchronous Automatic Stand-alone operation. They are connected together and one, the master, sends control instructions to the slaves. Up to 32 fixtures - both Profiles and Washes - can be operated this way.

To operate a single fixture

- 1 Scroll to *SA* in the main menu, press [enter], scroll to *Ctr*, press [enter], scroll to *Sn*, and press [enter].
- 2 Scroll to *ENA*, press [enter], scroll to *On* or *Aut*, and press [enter].
- 3 Modify behavior with the options in Table 6. (If the fixture does not respond as expected, verify that *Programmed* Stand-alone mode is disabled, i.e., that *Ctr/run* is set to *OFF*.)
- 4 Disconnect the fixture from power to stop operation.
- 5 To disable stand-alone operation, set *ENA* to *OFF*.

To operate multiple fixtures

Important! ***Set only 1 fixture as master: errors and damage can occur if there is more than 1 device sending control signals.***

- 1 Select any one fixture to be the master. On this fixture only, scroll to *SA* in the main menu, press [enter], scroll to *Ctr*, press [enter], scroll to *Sn*, and press [enter].
- 2 On all slave fixtures, scroll to *SA* in the main menu, press [enter], scroll to *Ctr*, press [enter], scroll to *rEC*, and press [enter].

- 3 Plug a data cable into the OUT socket of the first fixture and the IN socket of the next fixture. Repeat as required to connect up to 32 MiniMACs (Profiles and Washes).
- 4 Insert a female termination plug (P/N 91613018) into the IN socket of the first fixture. Insert a male termination plug (P/N 91613017) into the OUT socket of the last fixture. A termination plug is an XLR connector with a 120 ohm, 0.25 W resistor soldered across pins 2 and 3.
- 5 On all fixtures, scroll to `EN A`, press [enter], scroll to `On` or `Au t`, and press [enter]. (If a fixture does not respond as expected, verify that *Programmed Stand-alone* mode is disabled, i.e., that `C t r / r u n` is set to `OFF`.)
- 6 Set the trigger and pan/tilt options using the control panel on the master fixture. Set the color and gobo options on the slave fixtures. See Table 6. Note: The inverse pan and inverse tilt personalities may also be used to modify behavior. See Table 4.
- 7 To stop operation, simply disconnect the fixture from power. To disable stand-alone operation, set `EN A` to `OFF`.

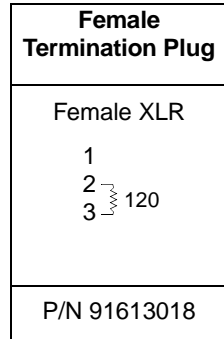

Setting	SA mode	Path	Option	Effect (Default setting bold)
SA enable	all	EnA	ON	Enable stand-alone operation
			OFF	Disable stand-alone operation
			Aut	Enable stand-alone operation automatically if there is no DMX signal for 5 seconds.
SA trigger	single, master	trg	Snd	Sound trigger
			Aut	Timed trigger
SA trigger rate	single, master	rAt	0.5 - 10	Set timed trigger pulse from 0.5 to 10 seconds
SA control mode	single	Ctr	sin	Set-up a single fixture
	master		Snd	Set-up a master fixture
	slave		rEC	Set-up a slave fixture
Low pan position	single, master	POS / PAN / Lo	0..255	Set one end of pan range
High pan position		POS / PAN / HI	0..255	Set other end of pan range
Low tilt position		POS / tIL / Lo	0..255	Set one end of tilt range
High tilt position		POS / tIL / HI	0..255	Set other end of tilt range
Pan/tilt speed	single, master	SPd	FSt	Select fast movement
			nor	Select medium speed movement
			SLO	Select slow movement
Slave color	slave	COL	nor	Slave color same as master
			Inu	Slave color opposite master
			rnd	Random slave color
Slave gobo	slave	Gob	nor	Slave gobo same as master
			Inu	Slave gobo opposite master
			rnd	Random slave gobo
Strobe	single, master	Stb	ON	Enable strobe function
			OFF	Disable strobe function
Defaults	all	FAC	-	Restore factory default stand-alone settings

Table 6: Stand-alone parameters

PROGRAMMED STAND-ALONE

7

In Programmed Stand-alone mode the MiniMAC executes up to 7 scenes created by the operator and stored in the fixture's memory. Scenes are programmed from the control panel or MPBB, and executed from the control panel or an MC-X Controller.

Multiple Profiles and Washes may be connected for operation in which each fixture either (1) mimics the master fixture, (2) executes its own scenes in synchronization with the others, or (3), using the MC-X controller, executes its own scenes with its own fade and wait times.

To connect multiple fixtures

See also "Data connection" on page 18.

- 1 Plug a data cable into the OUT socket of the first fixture and the IN socket of the next fixture. Repeat as required to connect up to 32 MiniMAC Profiles and Washes.
- 2 Insert a male termination plug (P/N 91613017) into the OUT socket of the last fixture. If you are not using an MC-X, insert a female termination plug (P/N 91613018) into the IN socket of the first fixture.

To program a single or master fixture routine

- 1 Select **C t r** from the main menu and press [enter].
- 2 One-by-one, select effects from the **C t r** menu, press [enter], scroll to the desired effect setting, and press [enter]. See Table 7.
- 3 To save a scene, scroll to **S t o** and press [enter]. Select any scene from **P 1** to **P 7** and press [enter]. A dash in the display indicates that a scene has already been saved in the location: it will be overwritten when you press [enter].
- 4 Program additional scenes as desired.
- 5 To retrieve a scene for viewing, editing, or to use as the starting point for a new scene, select **G E t** from the **C t r** menu, press [enter], select the desired scene number and press [enter]. Press [menu] to return to the **C t r** menu. Note: unprogrammed scenes do not appear in the **G E t** menu.
- 6 To delete scenes, select **d E L** from the **C t r** menu and press [enter]. Select the scene to delete or select **A L L** to delete all scenes. Unprogrammed scenes do not appear in the menu. Press [enter] to delete or press [menu] to escape.

Item	Fixtures	Menu	Option	Effect
Shutter	Profile & Wash	SHU	Opn	Shutter open
			CLO	Shutter closed
			FSt	Fast strobe
			nor	Medium strobe
			SLO	Slow strobe
			rnd	Random strobe
			FOP	Fade to open (max. fade time = 4 s.)
			FCL	Fade to closed (max. fade time = 4 s.)
Color	Profile & Wash	COL	Opn	No color (open white)
			S 1 . . S 13	Split color 1..split color 13
			C 1 . . C 12	Color 1..color 12
			FSt	Fast rotation
			nor	Medium rotation
			SLO	Slow rotation
			rnd	Random color
Gobo selection	Profile	gOb	Opn	No gobo (open white)
			g 1 . . g 7	Gobo 1 - 7
Gobo rotation	Profile	rgO	StA	No rotation (static)
			r 1 . . r 16	Clockwise rotation, speed 1 (slowest)... speed 16 (fastest)
			L 1 . . L 16	Counterclockwise rotation, speed 1 (slowest)...speed 16 (fastest)
			S 1 . . S 6	Gobo shake, speed 1 (slowest)...speed 6 (fastest)
Pan	Profile & Wash	PAn	0 . . 255	Pan position, left to right
Tilt	Profile & Wash	tIL	0 . . 255	Tilt position, up to down
Store scene	Profile & Wash	Sto	P 1 . . P 7	Store scene 1 to 7. Dash in display (P - 1) indicates saved scene.
Retrieve scene	Profile & Wash	gEt	P 1 . . P 7	Retrieve scene 1 to 7
Delete scene	Profile & Wash	dEL	P 1 . . P 7	Delete selected scene
			ALL	Delete all scenes

Table 7: Programmed Stand-alone commands

Item	Fixtures	Menu	Option	Effect
Wait time	Profile & Wash	trg	0 . 0 ... 1 2 0	Time, in seconds, that scenes hold still. Setting applies to all scenes. <i>If wait time is 0, then fade time must be greater than 0!</i>
			SLA	Slave (fixture runs master's scenes and timing)
			SYn	Synchronize (fixture runs own scenes using master's timing)
Fade time	Profile & Wash	FAd	0 . 0 ... 6 0	Transitions time, in seconds, between 2 scenes. Does not apply to colors and gobos. The maximum shutter fade is 4 seconds regardless of setting. <i>If fade time is 0, then wait time must be greater than 0!</i>
Run	Profile & Wash	run	OFF	Disable Programmed S/A mode. <i>Required for DMX or Automatic S/A mode!</i>
			Si n	Set S/A mode on a single fixture.
			Snd	Set S/A mode on a master fixture (send commands)
			rEc	Set S/A mode on a slave or synchronized fixture (receive commands). <i>Note:</i> slave = rEc + trg/SLA sync. = rEc + trg/SYn

Table 7: Programmed Stand-alone commands

To set fade and wait times

Important! Do not set both fade and wait to 0.

- 1 Select Ctr from the main menu and press [enter].
- 2 Select trg from the Ctr menu and press [enter].
 - To set a **single** or **master** fixture, select a wait time from 0.0 to 120 seconds.
 - To set a **slave** fixture, select SLA .
 - To set a **synchronized** fixture, select SYn.
Press [enter].
- 3 Select FAd from the Ctr menu and press [enter]. Select a fade time from 0 to 60 seconds and press [enter].

To execute the routine from the control panel

- 1 Select `run` from the `Ctrl` menu and press [enter].
 - To set a **single** fixture, select `Sin`.
 - To set a **master** fixture, select `Snd`.
 - To set a **slave** or a **synchronized** fixture, select `Rec`.Press [enter].
- 2 Press [menu] to exit the `Ctrl` menu. Execution begins.
- 3 To disable execution, select `Ctrl > run > OFF` and press [enter].

To execute scenes with an MC-X Controller

- 1 Connect the MC-X controller to the MiniMAC's data input. If multiple MiniMACs are connected, plug the controller into the first fixture in the link.
- 2 On each fixture, set fade and wait times as described above. Set `Ctrl > run > OFF` and press [enter].
- 3 To trigger individual scenes, press the Preset buttons on the MC-X.

The fixture or fixtures fade to the selected scene and then hold until another button is pressed. If a fixture does not have a scene programmed at the selected number, it executes the last-received DMX commands since the fixture was powered up. If the fixture has not received DMX commands, it goes to its default (blackout) position.

- 4 To have each fixture run it's routine, press [Auto].

COMPATIBLE LAMPS

The MiniMAC is designed to use either the Martin Metal Halide 150, included, or the Osram HTI 150 discharge lamp.

Important! *Installing any other lamp may damage the fixture.*

Lamp	Efficiency	Color Temp.	Average Life
MMH 150	67 lm/W	5000K	2000 hr.
HTI 150	67 lm/W	6500K	750 hr.

Table 8: Lamp specifications

To replace the lamp

WARNING! *Wear safety glasses and allow the lamp to cool for at least 5 minutes before opening the head.*

- 1 Disconnect the fixture from power and allow it to cool.
- 2 Pry/pull open the lamp access cover from the ribbed end.

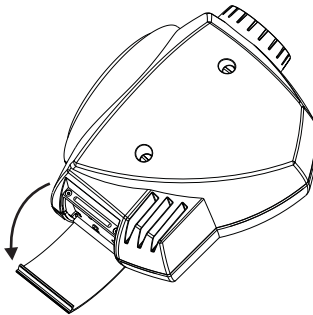

- 3 Remove the 3 outside screws (A) with a Pozidriv #1 screwdriver and remove the lamp socket assembly.
- 4 Remove the old lamp from the socket.

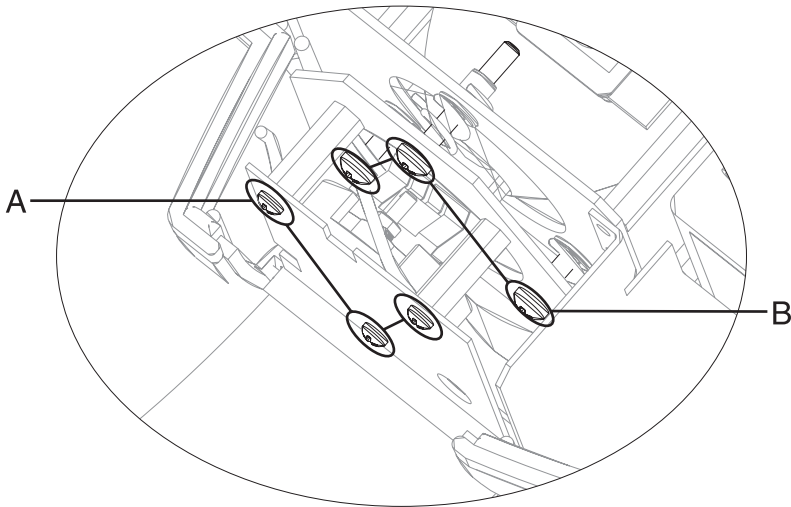

- 5 Holding the new lamp by its ceramic base (do not touch the glass), align the small pin with the small hole and insert the lamp squarely into the socket. Make sure that the 4 small projections on the base contact the socket.
- 6 If your fingers touched the glass bulb, clean it with a clean, lint-free cloth wetted with alcohol.
- 7 Insert the lamp assembly and replace the screws (A).
- 8 Reset the lamp hour and lamp strike counters as described on page 16.

To align the lamp

The lamp is pre-aligned at the factory. Realignment when changing the lamp may improve performance.

- 1 Strike the lamp and shine the light on a flat surface.
- 2 Center the hot-spot (the brightest part of the beam) with small turns of the adjustment screws (B) using a Pozidriv #2 screwdriver. If there is no hot-spot, adjust the reflector until the light is even.
- 3 To reduce a hot-spot, turn all 3 screws clockwise (B) 1/4-turn at a time until the light is evenly distributed.
- 4 If the light is brighter around the edge than it is in the center, or if light output is low, the lamp is too far back in the reflector. Turn the adjustment screws (B) counterclockwise 1/4-turn at a time until the light is bright and evenly distributed.
- 5 If you have trouble aligning the lamp, remove the lamp and check that it is seated squarely in the socket.

The MiniMAC Profile uses gobos as specified on page 42. The positions of the standard gobos, as seen from front, are shown to right and the correct orientation for different gobo types is shown below. When in doubt, install gobos with the more reflective side towards the lamp.

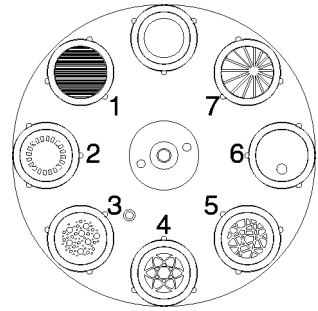

To change gobos

- 1 Turn off the lamp and allow it to cool for at least 5 minutes. Disconnect the fixture from power.
- 2 Unlock the head cover fasteners by turning them a quarter-turn counterclockwise. Pry open the lamp access cover from the ribbed end and remove the head cover.
- 3 Tilt the head up. Turn the gobo wheel as required to access the gobo. Squeeze the ends of the gobo spring together and remove it. Tilt the head down and catch the gobo as it falls out.
- 4 Tilt the head back up and drop the replacement gobo in the holder. Squeeze the spring together and carefully place it over the gobo.

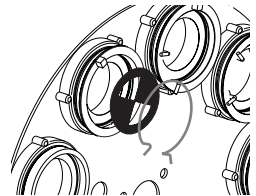

To focus gobos

- Project a gobo on a surface 2 meters or more away from the fixture. Turn the front lens as required to focus the pattern.

Coated glass gobos

Coated side towards lamp

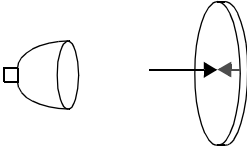

When an object is held up to the coated side there is no space between the object and its reflection. The back edge of the gobo cannot be seen when looking through the coated side.

Uncoated side towards stage

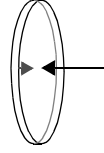

When an object is held up to the uncoated side there is a space between the object and its reflection. The back edge of the gobo can be seen when looking through the uncoated side.

Textured glass gobos

Smooth side towards lamp

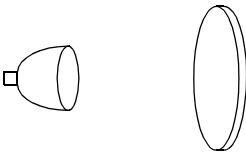

Textured side towards stage



Metal gobos

Reflective side towards lamp

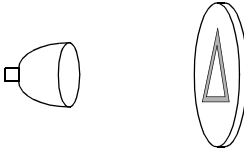

Black side towards stage



Image/text gobos

True image towards lamp

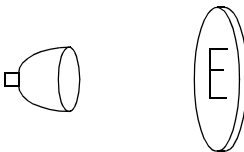

Reversed image towards stage



Gobo orientation

WASH FIELD ANGLE

The MiniMAC Wash optical system is factory-configured to provide a field angle of 40°, where the edge of the field is taken to be the circle where intensity is 10 percent of the center intensity. The field angle can be reduced to 23° by removing the lens and bracket located behind the Fresnel lens.

To configure for 23° field angle

Reverse this procedure to reconfigure for 40°.

- 1 Disconnect the fixture from power and remove the top cover (see page 33).
- 2 Remove the screws from the positions shown below-left with a Pozidriv No. 1 screwdriver.
- 3 Remove the lens and lens bracket and store safely.
- 4 Replace the screws as shown. Replace the top cover.

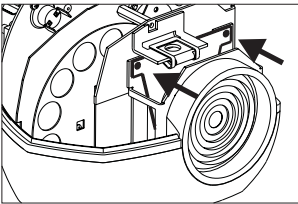

Remove screws

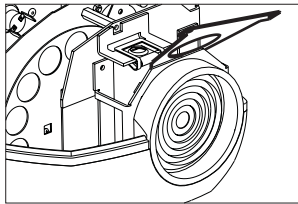

Remove lens and bracket

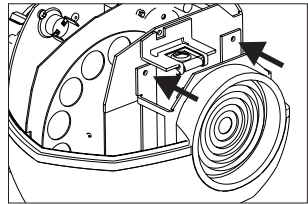

Replace screws

BASIC SERVICE

The MiniMAC requires simple routine maintenance. The schedule depends heavily on the operating environment; please consult a Martin service technician for recommendations.

Refer all service not described here to a qualified Martin technician.

Important! ***Excessive dust, grease, and smoke fluid buildup degrades performance and causes overheating and damage to the fixture that is not covered by the warranty.***

Warning! ***Disconnect the fixture from power before removing any cover.***

To open the head

- 1 Turn off the lamp and allow it to cool for at least 5 minutes. Disconnect the fixture from power.
- 2 Unlock the head cover fasteners by turning them a quarter-turn counterclockwise.
- 3 Open the lamp access cover by pulling from the ribbed end.
- 4 Pull off the top head cover.
- 5 When replacing the cover, turn the fasteners a half to a quarter turn clockwise until they click. *Do not overtighten.*

CLEANING

To clean optical components

Use care when cleaning optical components. The surface of the color filters is fragile and small scratches may be visible.

- 1 Disconnect the fixture from power and allow the components to cool completely. Remove the head cover.
- 2 Blow or vacuum away loose dust. Remove residues from lenses and filters with a soft cloth or cotton swabs wetted with isopropyl alcohol. Regular glass cleaner may also be used, but no residues may remain.

- 3 Rinse with distilled water. Mixing the water with a small amount of wetting agent such as Kodak Photoflo will help prevent streaking and spotting.
- 4 Dry with a clean, soft and lint-free cloth or blow dry with compressed air.

To clean the fan and air vents

To maintain adequate cooling, dust must be cleaned from the fan and air vents periodically.

- Remove dust and dirt from the fans and vent grills using a soft brush, cotton swab, vacuum, or compressed air.

INSTALLING SOFTWARE

Updates of the MiniMAC control software are released when features are added and improved. The latest version is available for download from the Service and Support area of the Martin Professional web site at <http://www.martin.dk>. Software is installed using a Martin uploader such as the MPBB1 with version 1.4 or later software.

To install software, normal method

Important! The data link must be terminated as described on page 19.

- 1 Download the latest control software from the Martin Professional web site at <http://www.martin.dk>. Install the software in a Martin MPBB1 uploader.
- 2 Connect the uploader to the fixture as you would a controller. Apply power to the uploader and the fixtures.
- 3 After the fixture has finished resetting, select `UPLd` from the uploader menu and press [enter]. Select `dMX` and press [enter]. Wait. The software has been installed when the MPBB1 displays `dONE` and the fixtures reset. Turn off and disconnect the MPBB1.
- 4 If a check-sum error (`CSE`) occurs and/or the fixture does not reset, data was interrupted or corrupted during transmission. Reattempt the upload using backup method I.

To install software, backup method I

Follow this procedure exactly as described to install software if a normal upload attempt is unsuccessful and a check-sum error (`CSE`) occurs.

- 1 Disconnect the fixture from power: it must be off at least 10 seconds. *Do not apply power to the fixture until the uploader is connected and ready.*

- 2 Connect the uploader to the fixture as you would a controller. *Terminate the link.*
- 3 Select `UPLd` from the uploader menu and press [enter]. Select `boot`. *Do not press [enter] yet.*
- 4 Apply power to the fixture. The control panel displays `CSE`, then `bSL`, then `b`. When `b` is displayed, *wait 5 seconds* and then press [enter] on the MPBB1.
- 5 Wait. The software has been installed when the MPBB1 displays `dONE` and the fixture resets. Disconnect the uploader.

To install software, backup method II

Use this procedure to install software only if all else fails.

- 1 Disconnect the fixture from the data link and power.
- 2 Use tweezers to move the jumper on PL107 on the main circuit board to the boot setting as shown.
- 3 Select `UPLd` from the uploader menu and press [enter]. Select `boot`. *Do not press [enter] yet.*
- 4 Connect the uploader to the fixture as you would a controller. *Terminate the link.*
- 5 Apply power to the fixture and wait 5 seconds.
- 6 Press [enter] on the MPBB1. Wait. The software has been installed when the MPBB1 displays `dONE` and the fixture resets.
- 7 Disconnect the fixture from power and move the jumper back to the normal setting.

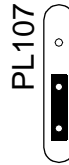

normal setting

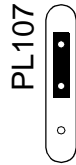

boot setting

REPLACING FUSES

The MiniMAC has 3 fuses. The main fuse is in the mains input socket. The secondary fuses are on the printed circuit board.

Warning! *Never replace fuses with ones of a different rating!*

To replace the main fuse

- 1 Unplug the mains cable from the input socket. Pry open the fuse holder and remove the fuse.
- 2 Replace the fuse with one of the same type. The fuse rating is listed on serial number label and in the specifications.

To replace secondary fuses

- 1 Disconnect the fixture from power.
- 2 Remove the 4 base cover bolts with a 4 mm Allen wrench. Move the cover without disconnecting wires.
- 3 Pry out the defective fuse and replace it with one of the same rating.
- 4 Replace the cover before applying power.

TROUBLESHOOTING

Problem	Probable cause(s)	Remedy
No response from fixture.	No power to fixture.	Check power cables.
	Primary fuse blown.	Replace fuse.
	Secondary fuse blown.	Replace fuse.
Fixture resets but does not respond correctly to controller.	Controller not connected.	Connect controller.
	Incorrect addressing of the fixtures.	Check address and mode settings on fixture and controller.
	Controller pin-out does not match fixture pin-out (signal reversed).	Insert a swapper cable in data input.
	Stand-alone mode enabled.	Verify that DMX address is displayed at top of menu. If not, disable stand-alone mode.
	Bad data link connection.	Inspect cables and correct poor connections and/or broken cables.
	Data link not terminated.	Insert termination plug in output of last fixture.
	Defective fixture or 2 devices transmitting on link.	Bypass fixtures one at a time until normal operation is regained: unplug both connectors and connect them directly together.
Fixture does not reset.	An effect requires adjustment.	Contact service technician.
No light.	Lamp missing or blown.	Disconnect fixture and replace lamp.
Lamp cuts out intermittently or burns out too quickly.	Fixture is too hot.	Allow fixture to cool.
	Incorrect power supply setting.	Check setting.
S t E (memory error) message displayed	The user settings cannot be read from memory.	Contact service technician.
P A E (pan error time-out) message displayed	Pan reset switch malfunction.	Contact service technician.
T I E (tilt error time-out) message displayed	Tilt reset switch malfunction.	Contact service technician.
CSE (check-sum error) message displayed	Unsuccessful software upload.	See "Installing software".

DMX PROTOCOL



MiniMAC Wash				MiniMAC Profile				Value	Percent	Function								
1	2	3	4	1	2	3	4											
1				1						Shutter, Strobe, Reset, Lamp On/Off <i>With shutter fade disabled (default)</i>								
										0 - 19	0 - 7	Shutter closed						
										20 - 38	7 - 14	Shutter open						
										<hr/>								
										0 - 38	0 - 14	<i>With shutter fade enabled</i> Dimmer, closed to open						
										<hr/>								
										39 - 49	15 - 19	Shutter open						
										50 - 112	19 - 44	Strobe, fast to slow						
										113 - 127	44 - 50	Shutter open						
										128 - 137	50 - 53	Random strobe, fast						
										138 - 147	54 - 57	Random strobe, medium						
										148 - 157	58 - 61	Random strobe, slow						
										158 - 167	62 - 65	Shutter open						
										168 - 177	66 - 69	Stand-alone w/ music trigger						
										178 - 187	70 - 73	Stand-alone w/ auto trigger						
										188 - 207	74 - 81	Shutter open						
208 - 217	81 - 85	*Reset																
218 - 227	85 - 87	Shutter open																
228 - 237	89 - 93	Lamp on																
238 - 247	93 - 97	Shutter open																
248 - 255	97 - 100	*Lamp off: hold for 5 seconds																
<hr/>																		
2				2						Color								
										0 - 150	0 - 59	Continuous scroll						
										0	0	White						
										12	4	Color 1 (CTC 5500>3400)						
										24	9	Color 2 (Pink 312)						
										36	14	Color 3 (Red 301)						
										48	18	Color 4 (Green 206)						
										60	23	Color 5 (Cyan 104)						
										72	28	Color 6 (Yellow 603)						
										84	33	Color 7 (Magenta 507)						
										96	37	Color 8 (Blue 101)						
										108	42	Color 9 (Green 208)						
										120	47	Color 10 (Purple 502)						
										132	52	Color 11 (Orange 306)						
144	56	Color 12 (Blue 108)																

MiniMAC Wash
MiniMAC Profile

1	2	3	4	1	2	3	4	Value	Percent	Function
2								151 - 159	59 - 62	Color Stepped scroll
								160 - 163	63 - 64	Color 12 (Blue 108)
								164 - 167	64 - 65	Color 11 (Orange 306)
								168 - 171	66 - 67	Color 10 (Purple 502)
								172 - 175	67 - 68	Color 9 (Green 208)
								176 - 179	69 - 70	Color 8 (Blue 101)
								180 - 183	70 - 72	Color 7 (Magenta 507)
								184 - 187	72 - 73	Color 6 (Yellow 603)
								188 - 191	74 - 75	Color 5 (Cyan 104)
								192 - 195	75 - 76	Color 4 (Green 206)
								196 - 199	77 - 78	Color 3 (Red 301)
								200 - 203	78 - 79	Color 2 (Pink 312)
								204 - 207	80 - 81	Color 1 (CTC 5500>3400) White
								208 - 245	81 - 96	Continuous rotation CW, fast to slow
								246 - 248	96 - 97	Random color
								249 - 251	98	Fast
								252 - 255	99 - 100	Medium Slow
-								0 - 20	0 - 7	Gobo Selection and Shake Gobo selection
								21 - 35	8 - 13	Open
								36 - 50	14 - 19	Fibroid texture glass
								51 - 65	20 - 25	Radial dashes
								66 - 80	26 - 31	Stardust 2
								81 - 95	31 - 37	Atomic 2
								96 - 110	37 - 43	Highways 2
								111 - 125	43 - 49	Decentered beam
								126 - 145	49 - 57	Sunburst 507
								146 - 165	57 - 65	Gobo shake, slow to fast
								166 - 185	65 - 72	Decentered beam
								186 - 205	73 - 80	Highways 2
								206 - 225	81 - 88	Atomic 2
								226 - 245	89 - 96	Stardust 2
								246 - 248	96 - 97	Radial dashes
								249 - 251	98	Fibroid texture glass
								252 - 255	99 - 100	Random gobo
		Fast								
		Medium								
		Slow								

MiniMAC Wash				MiniMAC Profile				Value	Percent	Function
1	2	3	4	1	2	3	4			
-				4				0 - 2	0	Gobo Rotation and Swing (select gobo on ch. 3) No rotation CW rotation, slow to fast CCW rotation, fast to slow No rotation
								3 - 117	1 - 46	
								118 - 232	46 - 91	Gobo swing, slow to fast
								233 - 239	91 - 94	
								240 - 255	94 - 100	
								3		
-	4	-	4	-	6	-	6	0 - 255	0-100	Pan fine (LSB) Left to right
4	5	4	5	6	7	6	7	0 - 255	0-100	Tilt Up to down (128 = neutral)
-	6	-	6	-	8	-	8	0 - 255	0-100	Tilt fine (LSB) Up to down
-				-				0 - 2	0	Pan/Tilt Speed Tracking mode Fast to slow Tracking, P t S = S L O Tracking, P t S = F S t Blackout while moving
								3 - 245	1 - 96	
								246 - 248	96 - 97	
								249 - 251	98	
								252 - 255	99 - 100	
								-		
-				-				3 - 251	1 - 96	
-				-				252 - 255	97 - 100	

SPECIFICATIONS

PHYSICAL

Length:	390 mm (15.4 in)
Width:	316 mm (12.4 in)
Height:	415 mm (16.3 in)
Weight, MiniMAC Profile:	11.8 kg (26.0 lbs)
Weight, MiniMAC Wash:	11.6 kg (25.5 lbs)

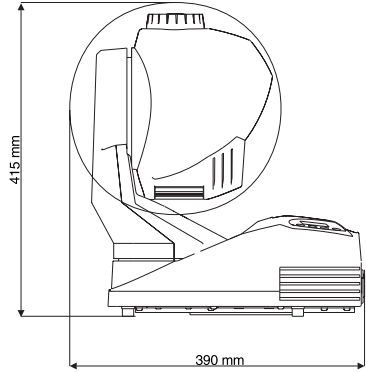
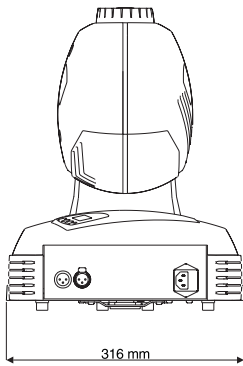

SOURCE

Martin Metal Halide 150 (included):	150 W, 67 Lm/W, 2000 hr., 5000K
Osram HTI 150 (optional):	150 W, 67 Lm/W, 750 hr., 6500K

OPTICS, MINIMAC PROFILE

Focused beam angle:	17°
Focus:2 m (6.5 ft.) to infinity
Outside gobo diameter:	22.5 mm + 0/- 0.3 mm (0.886 in +0/- 0.012 in)
Maximum gobo image diameter:	17.0 mm (0.669 in)
Maximum gobo thickness:	1.1 mm (0.043 in)

OPTICS, MINIMAC WASH

Standard field angle:	40°
Optional field angle (40° lens removed):	23°
Focus:	fixed

DATA COMMUNICATION

Hardware standard:	RS-485
Data I/O:	locking 3-pin XLR, pin 1 shield, pin 2 cold (-), pin 3 hot (+)
Recommended cable: ...	24 AWG (min.), low capacitance, 85-150 Ω shielded twisted pair

INSTALLATION

Mounting points:	1 pair of 1/4-turn locks
Orientation:	any
Minimum distance to combustible materials:	0.3 m (12 in)
Minimum distance to illuminated surfaces:	0.3 m (12 in)
Minimum clearance around fan and air vents:	0.1 m (4 in)

THERMAL

Maximum ambient temperature (Ta):	40° C (104° F)
Maximum surface temperature:	60° C (140° F)

AC SUPPLY

AC input:	3-pin IEC male socket
Power supply options:	100/120/210/230/250 V, 50/60 Hz (switch-selectable)

MAXIMUM POWER AND CURRENT

100 V, 50 or 60 Hz:	220 W, 2.7 A
120 V, 50 or 60 Hz:	210 W, 2.0 A
210 V, 50 or 60 Hz:	200 W, 1.3 A
230 V, 50 or 60 Hz:	200 W, 1.1 A
250 V, 50 or 60 Hz:	210 W, 1.0 A

FUSES

Primary fuse, 200 - 250 V:	T 3.15 A, high I ² t, 250 V
Primary fuse, 100 - 130 V:	T 3.15 A, high I ² t, 250 V
Fuse F401:	T 3.15 A, high I ² t, 250 V
Fuse F402:	T 2.5 A, 250 V

CONSTRUCTION

Housing:	UV-resistant fiber-reinforced composite
Finish, black:	integral color
Finish, titanium or white:	polyurethane coating
Protection factor:	IP 20

ACCESSORIES

G-clamp:	P/N 91602003
Half-coupler clamp:	P/N 91602005
Optional gobos:	MAC 250 size, see catalogue

